

SATELLITE IMAGE ORIENTATION

K. Jacobsen

Institute of Photogrammetry and Geoinformation
Leibniz University Hannover
jacobsen@ipi.uni-hannover.de

Commission I, WG I/5

KEY WORDS: Photogrammetry, Orientation, Calibration, Camera, Georeferencing, Satellite, Accuracy

ABSTRACT:

The number of high and very high resolution optical satellites, as well as the number of medium resolution small satellites is growing permanently. With the ground sampling distance (GSD) of 0.5m available now, a competition to aerial photographs down to the image scale 1 : 20 000 exists. The satellite image orientation is depending upon the image product. Mainly close to original images, traditionally named level 1A, and images projected to a plane with constant height, traditionally named level 1B, are available. The satellite image orientation may be based on a reconstruction of the image geometry, supported by some approximate orientation information in the image header file, or the orientation information distributed together with the image as rational polynomial coefficients can be used in a bias corrected manner. Another possibility are general approximate orientations like 3D-affine transformation, DLT or the generation of a reduced number of RPC-elements based on ground control points (GCP). The methods are analyzed and compared by means of different satellite image types.

1. INTRODUCTION

Without precise geo-referencing of satellite images the included very high resolution object information has only limited use. The continuing competition between space and aerial images is based on the information contents of the images, usually described by the effective GSD and the geometric potential. Based on aerial images well defined points can be determined with standard deviation in X and Y on sub-pixel level. A corresponding accuracy requires a good knowledge of the satellite orientation and changes within the scenes, if the orientation shall be done with a minimal number of control points. With simplified orientation procedures, just based on ground control points, accurate three-dimensional orientations have some limitations, a direct or indirect reconstruction of the imaging geometry has advantages.

2. IMAGE GEOMETRY

With very few exceptions, optical satellites are CCD-line scanners. This is reducing the calibration to the geometry of a line. In the flight direction the images are generated by the movement and rotation of the satellite; that means in the flight direction the image geometry is a function of the exterior orientation. The optical sensors, including the components like CCD-lines, are calibrated before launch, but it cannot be guaranteed, that the sensor geometry is not affected by the extreme acceleration during launch and the conditions in space, requiring also an in-flight calibration (Kornus et al 1999). The laboratory and the in-flight calibration are respected in the

generation of distributed images, so the standard user has not to take care about it.

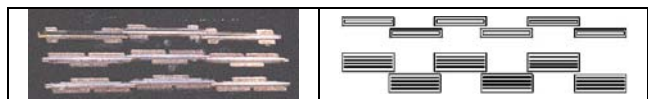

Fig. 1: left: CCD-line configuration of IKONOS
© SpaceImaging, right CCD-line configuration QuickBird

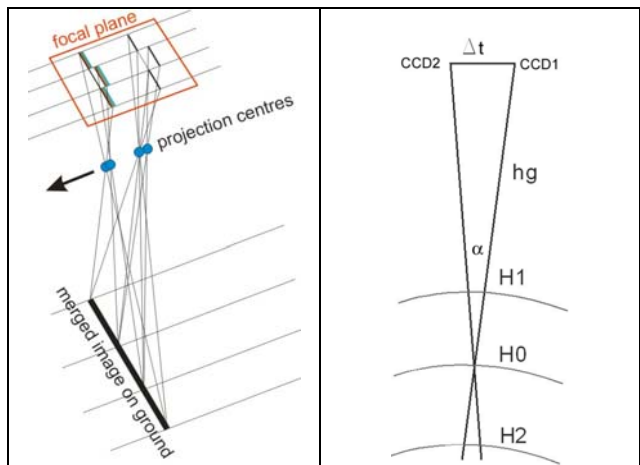

Fig. 2: left: combination of CCD-lines to a homogenous line in object space right: mismatch of the sub-CCD-lines depending upon object height

For the integration and read-out of a CCD-line of satellite sensors, only a very short time is available, like for example 70μsec for WorldView-1. This is not a sufficient time for the read out of long CCD-lines. In addition the length of CCD-lines is limited; so optical satellites are combining some up to several CCD-lines like shown in figure 1. The sub-CCD-lines cannot be aligned without gaps, requiring a shift in the orbit direction. The

images of the sub-CCD-lines are mixed together, using tie points in the overlapping part of the sub-images for calibration (Jacobsen 1997). The different sub-images have different projection centres (Fig. 2 left), so by theory the merging of the sub-images is only correct for the reference height H_0 . For another height level like H_1 or H_2 (Fig. 2 right), the sub-images will not fit precisely. For most sensors this misfit of the sub-image merge is more theoretical, for example for QuickBird a misfit of 1 pixel appears for a height difference against the reference height of 2.8km. Under usual conditions the calibration of the commercial sensors is sufficient, so no remarkable error in the CCD-lines or a bending of the CCD-lines has to be expected.

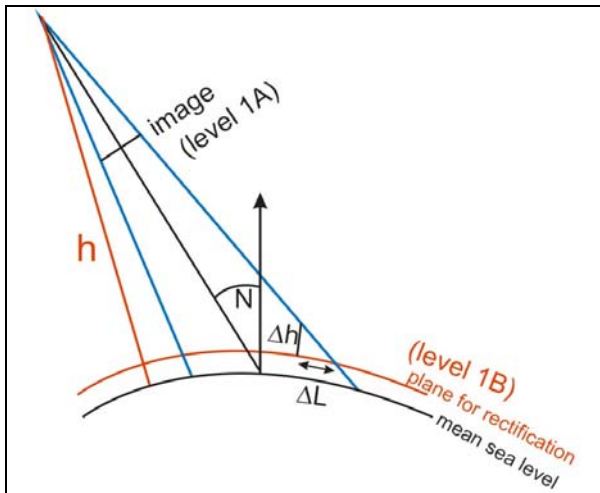

Fig. 3: image products

Satellite images are distributed as close to original images, named as level 1A or Basic or they are projected to a plane with constant height, named as level 1B or IKONOS Geo or OR-Standard. Images projected to a rough height model like GTOPO30, available as QuickBird Standard, do not play an important role. Further on the expressions level 1A and level 1B are used, even if some distributors use this in a different manner.

Level 1B images are dominating for very high resolution images, so IKONOS images are only distributed in this form and from other distributor's sub-scenes are distributed only as such a product. On the other hand stereo scenes like from Cartosat-1 are preferred as level 1A. Finally it is not so important what a product is used, so for example the same SPOT-5 stereo combination has been used for the generation of height models as level 1A and separately as level 1B, leading to very similar results (Jacobsen 2004).

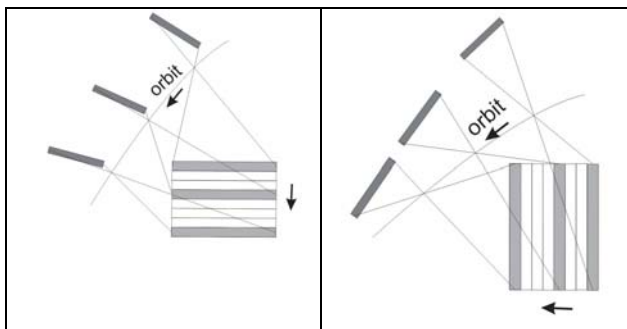

Fig. 4: CCD-line orientation during imaging

Traditionally the sensor orientation was fixed against the orbit during imaging. This has changed with the new generation of flexible satellites; they are equipped with reaction wheels or control moment gyros, allowing a fast and precise rotation of the satellite together with the optical system even during imaging. As shown in figure 4, the flexible satellites are able to generate images exactly in the North-South direction, in East-West direction and any other direction. IKONOS is also able to scan the ground against the movement of the satellite.

The sampling rate of some satellites does not agree with the satellite speed in the orbit and the GSD, requiring an asynchronous imaging mode with permanent change of the view direction during imaging (figure 5). Usually the asynchronous imaging mode has no negative influence to the image geometry, but it reduces the imaging capacity of the satellite at least by the slow down factor B/A .

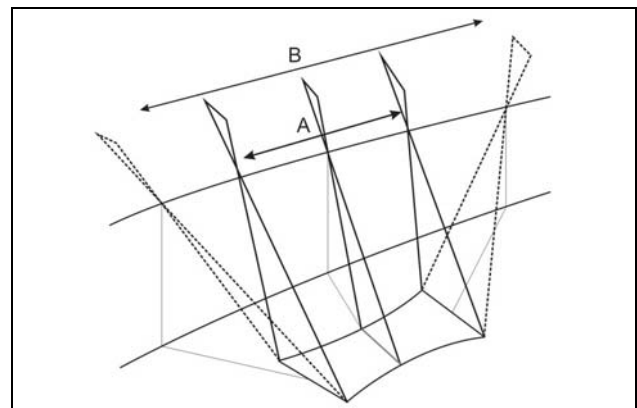

Fig. 5: asynchronous imaging mode as dashed lines

3. IMAGE ORIENTATION

The image orientation determines the relation between the object and the image coordinates. This has to respect the image product and the imaging mode. Based on direct sensor orientation, a combination of GPS-positioning, gyros and star sensors, the relation between the image and the object is known at least approximately, for example IKONOS orientations are known without ground control points (GCP) on the level of 4m standard deviation. For other satellites this may be not so precise. In general the satellite image has to be related to the used national coordinate system with sometimes not well known or published datum. So at least for reliability, control points are required.

The image orientation may be based on a geometric reconstruction of the imaging geometry, depending upon the available information. The direct sensor orientation may be available also as sensor oriented rational polynomial coefficients (RPC). Like the geometric reconstruction this has to be improved by control points, named also bias corrected. In addition approximate orientation solutions just based on control points and not using any known pre-information about the orientation, are used like: 3D-affine transformation, direct linear transformation (DLT) and terrain related RPCs, which are just based on control points. These approximate orientation methods are not only requiring control points well distributed in the scene, for the reconstruction of the view direction also three-dimensional well distributed control points are necessary. Even in mountainous areas this may be difficult, because control points usually are only available in the valleys.

3.1 Geometric Reconstruction

The geometric reconstruction is in common use since the availability of high resolution space images, starting with SPOT 1986. Together with the images, information about the position in the orbit and attitude data are distributed. This is still today the case for several satellites. In addition to the orbit positions also the general orbit information in form of satellite inclination and semi-major and -minor axis of orbit ellipse are published. They can be used instead of the coordinate positions together with the attitude data. Such a solution is used in the Hannover program BLASPO – just with the general satellite orbit, respecting the earth rotation, and the view direction together with few control points, the imaging geometry can be reconstructed. This can be improved with few additional parameters. Sub-pixel accuracy can be reached with just 3 control points even for longer image strips. This general solution can be used for all level 1A images, like for example QuickBird Basic imagery (Jacobsen, Passini 2003) or OrbView-3 Basic (Buyuksalih et al, 2006). A higher number of slightly different solutions are in use. The number of required control points depends upon the strength of the geometric reconstruction. Not so precise models reconstructing the geometry by using partially polynomial solutions are requiring more and well distributed control points.

For images projected to a plane with constant height, the geometric reconstruction is also not complicate. Originally Space Imaging did not like to give some information about the image orientation to the user. The header data was including mainly the scene location in the ground coordinate system and for the scene centre the nominal collection elevation and azimuth. In addition the information about scan direction was given. So from the scene centre the direction to the orbit was available with the nominal collection elevation and azimuth. This vector can be intersected with the general satellite orbit (figure 6), leading to the ephemeris. The distance B in the scan direction of the scene can be used to determine the distance from the projection centre corresponding to the actual projection centre for any scene line. This has to respect the change of the ephemeris as function of the time, the earth rotation and possible slow down factors, like in the case of QuickBird and also the scan direction which may be different from North South. So the projection centre for any scene line can be computed in the national coordinate system – this includes the full orientation information because the attitude is available by the direction from the actual projection centre to the corresponding ground point.

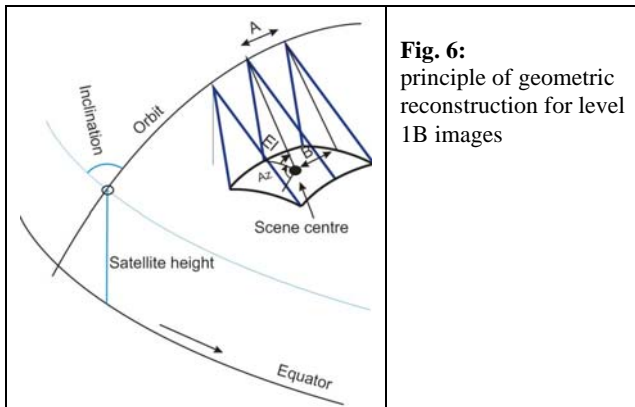

Fig. 6: principle of geometric reconstruction for level 1B images

This geometric reconstruction can be based just on the given information without any control points. If the actual location

shall be checked or improved, control points are required. As shown in figure 3, an imaged object point must not be located in the reference plane for rectification - a height difference Δh is causing a shift ΔL of the location. With given object height, the point location in the national coordinate system can be computed, named also terrain relief correction. After this correction a two-dimensional relation to the control points can be determined. Experiences showed that for IKONOS images a simple shift was sufficient if the reference height of the plane of rectification is available. For most other space images a two-dimensional affine transformation is required to reach sub-pixel accuracy. This determines the required number of control points – for a shift by theory only one control point is necessary, for a two-dimensional affine transformation 3. But in no case the orientation should be made without over-determination to reach a sufficient level of reliability.

3.2 Sensor Oriented RPC

Instead of the information used for geometric reconstruction, the direct sensor orientation may be given also by the replacement model of rational polynomial coefficients. Based on the direct sensor orientation the relation between a ground point, given by it's coordinates X, Y, Z and the image point x, y, is known. Around the terrain a cube of points is generated (figure 7) with knowledge of the corresponding ground and image coordinates. With such corresponding object and image coordinates the RPC-coefficients are adjusted (formula 1).

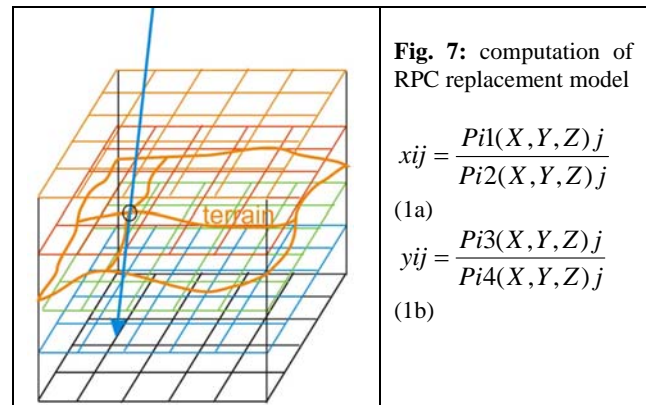

Fig. 7: computation of RPC replacement model

$$x_{ij} = \frac{Pi1(X,Y,Z)_j}{Pi2(X,Y,Z)_j} \quad (1a)$$

$$y_{ij} = \frac{Pi3(X,Y,Z)_j}{Pi4(X,Y,Z)_j} \quad (1b)$$

$$Pn(X,Y,Z)_j = a_1 + a_2*Y + a_3*X + a_4*Z + a_5*Y*X + a_6*Y*Z + a_7*X*Z + a_8*Y^2 + a_9*X^2 + a_{10}*Z^2 + a_{11}*Y*X*Z + a_{12}*Y^3 + a_{13}*Y*X^2 + a_{14}*Y*Z^2 + a_{15}*Y^2*X + a_{16}*X^3 + a_{17}*X*Z^2 + a_{18}*Y^2*Z + a_{19}*X^2*Z + a_{20}*Z^3 \quad (1c)$$

Formula 1. Rational polynomial coefficients.

x_{ij}, y_{ij} = normalized scene coordinates
 X, Y = normalized geographic object coordinates
 Z = height

The RPCs are expressing with 80 coefficients the relation between the image and the ground coordinates. By the ratio of 3rd order polynomials usually with sufficient accuracy any geometric relation can be expressed.

Like for the geometric reconstruction, control points are required for reliability and higher accuracy. After a corresponding terrain relief correction, the same 2D-transformation like for the geometric reconstruction is required. In the last years the use of the RPC-replacement model increased.

3.3 3D-Affine Transformation

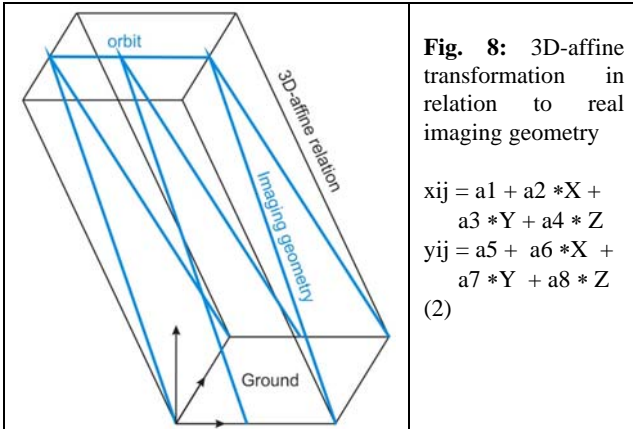

Fig. 8: 3D-affine transformation in relation to real imaging geometry

$$\begin{aligned} x_{ij} &= a_1 + a_2 * X + a_3 * Y + a_4 * Z \\ y_{ij} &= a_5 + a_6 * X + a_7 * Y + a_8 * Z \end{aligned} \quad (2)$$

$$\begin{aligned} x_{ij} &= a_1 + a_2 * X + a_3 * Y + a_4 * Z + a_9 * X * Z + a_{10} * Y * Z + a_{13} * X * X \\ y_{ij} &= a_5 + a_6 * X + a_7 * Y + a_8 * Z + a_{11} * X * Z + a_{12} * Y * Z + a_{14} * X * Y \end{aligned}$$

Formula 3: extended 3D-affine transformation for original images

The 3D-affine transformation (formula 2) expresses the relation between the ground coordinates and the image coordinates without any pre-information about the imaging geometry. The 3D-affine transformation is the mathematical model for a parallel projection, which exists only approximately in the orbit direction if no slow down factor is used, but the perspective geometry in the CCD-line is neglected (figure 8). In the case of larger object height variation, positional errors cannot be avoided. For the 3D-solution control points in 3D distribution are required. The perspective geometry and a slow down factor of asynchronous imaging can be respected with the additional terms a_9 up to a_{12} (formula 3) – named extended 3D-affine transformation. For level 1A-images the whole formula 3 with 14 unknowns is required, needing at least 7 control points.

3.4 Direct Linear Transformation

Another approximate solution, not using any pre-information about the imaging geometry, is the direct linear transformation (DLT). With 11 parameters it is expressing the inner and exterior orientation of a perspective image. The DLT is not respecting the close to parallel projection in the orbit direction. The 11 unknowns require at least 6 three-dimensional distributed control points.

$$\begin{aligned} x_{ij} &= \frac{L_1 * X + L_2 * Y + L_3 * Z + L_4}{L_9 * X + L_{10} * Y + L_{11} * Z + 1} \\ y_{ij} &= \frac{L_5 * X + L_6 * Y + L_7 * Z + L_8}{L_9 * X + L_{10} * Y + L_{11} * Z + 1} \end{aligned} \quad (4)$$

Formula 4: DLT transformation

3.5 Terrain dependent RPCs

A selected number of coefficients from formula 1 can be determined just based on control points and the corresponding image points. The number of parameters depends upon the available control points and their distribution. The commercial software packages providing this method do not give any

information about the correlation and determinability of the unknowns. Even if the residuals at the control points are small, the solution may fail totally with errors of 500m in the case of an orientation of IKONOS images. This method is not serious and should never be used.

4. EXPERIENCES

With geometric reconstruction or sensor depending RPC-solution, in general sub-pixel accuracy of the object points can be reached with well determined control and check points (table 1). If no accuracy of 1 GSD has been reached for the projects listed in table 1, there was a special problem, in most cases with limited accuracy of the control and check points. In the case of OrbView-3 the ground resolution of 1m is reached by over-sampling of neighbored pixels of a staggered CCD-line by 50% that means the projected pixel size is 2m, avoiding higher object point accuracy.

Based on one image only the direction to the ground point is known, requiring the object height for the determination of the location.

	level	GSD [m]	SX/SY [m]	SX/SY [GSD]
ASTER,Zonguldak	A	15	10.8	0.7
KOMPSAT-1, Zon.	A	6.6	8.5	1.3
SPOT, Hannover	A	10	4.6	0.5
SPOT-5, Zonguldak	A	5	5.2	1.0
SPOT-5, Zonguldak	B	5	5.1	1.0
SPOT HRS, Bavaria	A	5x10	6.1	0.7/1.1
IRS-1C, Hannover	A	5.7	5.1	0.9
IRS-1C, Zonguldak	B	5.7	9.1	1.6
Cartosat-1, Warsaw	A	2.5	1.4	0.8
OrbView-3, Zong.	A	1 (2)	1.3	1.3
IKONOS, Zonguld.	B	1	0.7	0.7
QuickBird, Zongul.	B	0.61	0.5	0.8
WorldView-1, Istan.	B	0.5	0.45	0.9

Tab. 1: standard deviation of sensor orientation at check points based on geometric reconstruction or bias corrected sensor oriented RPC-solution

4.1 WorldView-1 (0.5m GSD)

A WorldView-1 scene of Istanbul city has been investigated. Because of the large size, the scene is subdivided into tiles, but this is not influencing the geometry.

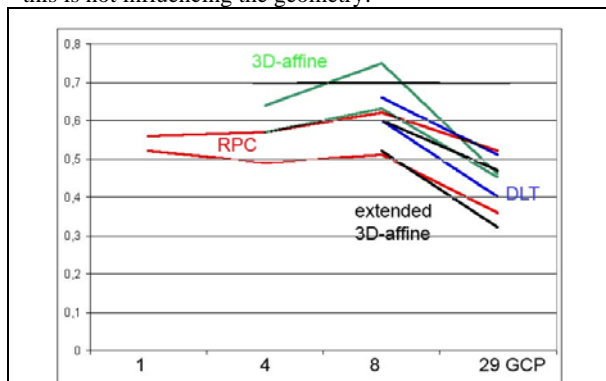

Fig. 9: accuracy of point determination by WorldView-1, Istanbul, depending upon number of control points; upper line = standard deviation in view direction, lower line across

The scene has a nadir angle of 32.6° , so the object point height is strongly influencing the location. The orientation by bias corrected sensor oriented RPC-solution has been corrected after terrain relief correction just by a shift and also a 2D-affine transformation to the control points. The 2D-affine transformation improved the results only in the case of an adjustment with all control points by 10%, for the adjustments with a smaller number of control points the results at independent check points was on the same level, nevertheless 4 of the affine parameters have been significant.

The upper line of the same type of orientation in figure 9 is always in the view direction, while the lower line is across the view direction. The different accuracy is caused by the height of the control points, which has approximately 50cm standard deviation. The component across the view direction is not influenced by this and gives a better impression about the accuracy potential.

The control points are located in a height between sea level and 192m. With the small field of view of the used points, located only in one image tile, this has only a limited influence to the approximate solutions. The 3D-affine transformation can also be handled with 4 control points, but is not reaching the accuracy level of the bias corrected RPC-solution. The other methods are starting with 8 control points, but both further used solutions are not on the same level like the RPC-solution.

4.2 QuickBird (0.61m GSD)

In the flat area of Atlantic City, USA, with height differences of just 19m, the approximate orientation solutions failed with QuickBird Basic Imagery (level 1A). With geometric reconstruction a standard deviation of the coordinate components at 355 check points of approximately 0.7m has been reached based on 25 control points. With the same constellation even the extended 3D-affine transformation reached only approximately 5m and the DLT 9m.

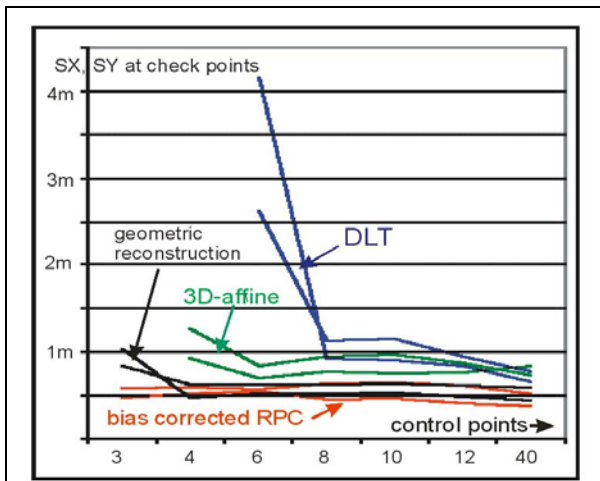

Fig. 10: orientation of QuickBird, Zonguldak (mountainous); root mean square discrepancies at independent check points as function of GCP number - 40 GCPs = discrepancies at GCPs

In the mountainous test area Zonguldak, Turkey, with 440m height difference of the control points, the orientation of a QuickBird OR Standard (level 1B) image with the approximate orientation methods was quite better (figure 10). Nevertheless with the rigorous methods especially with a smaller number of control points better results have been achieved. With the exception of the orientation with 3 control points the geometric

reconstruction and the bias corrected, sensor oriented RPC-solution are on the same level. The orientation with just 3 control points is not serious because no over-determination exists with the required 2D-affine transformation after terrain relief correction. With just a shift instead of the 2D-affine transformation the root mean square discrepancies are in the range of 2m.

4.3 IKONOS (1m GSD)

In the same area IKONOS images have been investigated. Opposite to QuickBird, the bias corrected RPC-solution shows slightly better results like the geometric reconstruction. The behaviour of the approximate solutions is similar to QuickBird. The approximate solutions need more and three-dimensional well distributed control points, but the field of view of IKONOS is only half of the value for QuickBird and so the loss of accuracy in relation to the GSD is smaller for IKONOS like for QuickBird. In both cases the DLT needs at least 8 control points, while the 3D-affine transformation is acceptable with 6 control points (figure 11), nevertheless they are not reaching the accuracy of the geometric reconstruction and the bias corrected RPC-solution.

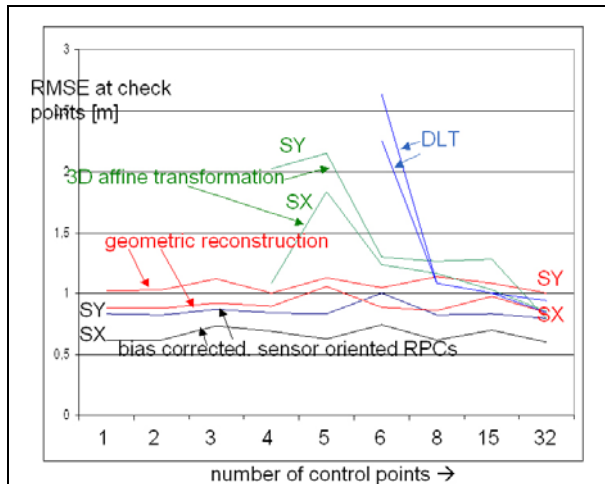

Fig. 11: orientation of IKONOS scene, Zonguldak; root mean square discrepancies at independent check points as function of GCP number - 32 GCPs = discrepancies at GCPs

In a random selection of 4 control points, well distributed in the X-Y-plane, poor results with up to $RMSY=18m$ has been achieved with the 3D-affine transformation. The reason was the location of all 4 control points close to an inclined plane. The Hannover program TRAN3D indicated this by a warning about large correlation of the unknowns, but the commercial programs did not show any problem. Similar poor results have been achieved with the 3D-affine transformation in a flat area of New Jersey with up to root mean square discrepancies of 7m. The DLT even has more problems indicated by correlations listed with values 1.00, that means exceeding 0.995.

4.4 OrbView-3 (1m GSD, 2m projected pixel size)

An edge analysis (Jacobsen 2008b) showed an effective resolution of OrbView-3 images less by a factor 1.3 in relation to IKONOS-images. Corresponding to this, with the same control points like used before for IKONOS and QuickBird, not a ground coordinate accuracy of 1 GSD was possible by

orientation of an OrbView-3 Basic (level 1A) stereo pair. As shown in figure 12, also the bias corrected RPC-solution requires at least 4 control points for reaching root mean square differences at check points in the range of 2m. On the other hand, based on all control points, the vertical accuracy is approximately 1.8m.

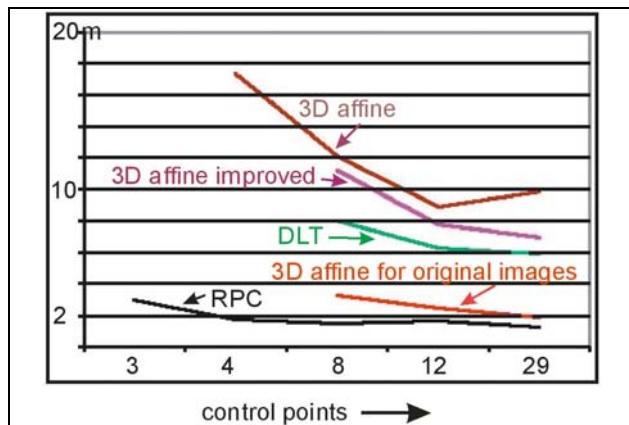

Fig. 12: Orientation of OrbView-3 Basic, Zonguldak – root mean square differences at independent check points depending upon number of used control points

The standard approximate solutions DLT and 3D-affine transformation are not reaching acceptable results. This is not astonishing, because the scene projected to the ground has not parallel sides. Only with the 3D-affine transformation for original images (formula 3), the results are not too far away from acceptable.

4.5 Cartosat-1 (2.5m GSD)

From Cartosat-1 original images (level 1A) have been investigated (Jacobsen et al 2008b). The results achieved in a flat area with 43m height differences are shown in table 2 and the results of a smoothly mountainous area with 1290m height differences in table 3.

	RMSX	RMSY
sensor oriented RPC	1.94 m	1.57 m
3D-affine transformation	2.48 m	4.23 m
3D-affine transf. for original images	2.90 m	5.96 m
DLT	2.78 m	4.69 m

Tab. 2: orientation of 2 Cartosat-1 images – root mean square errors at independent check points, based on 8 control points, Warsaw – $\Delta h = 43m$

	RMSX	RMSY
sensor oriented RPC	1.95 m	1.50 m
3D-affine transformation	19.98 m	3.40 m
3D-affine transf. for original images	3.62 m	1.56 m
DLT	failed	

Tab. 3: orientation of 2 Cartosat-1 images – root mean square errors at independent check points, based on 12 control points, Jordan – $\Delta h = 1290m$

The sensor oriented RPC-solution even with just 4 control points reached at check points root mean square discrepancies of 2.29m, that means sub-pixel accuracy. In the flat area the results achieved with the approximate solutions are not too far

away from acceptable, but in the mountainous area the DLT failed totally with errors of some km, while the standard 3D-affine transformation (formula 2) gave very poor results. Only the 3D-affine transformation for original images (formula 3) with 14 unknowns was near to acceptable.

CONCLUSION

The orientation of space images may be based on geometric reconstruction or bias corrected, sensor oriented RPCs. Both methods lead approximately to the same accuracy under all investigated conditions. The approximate image orientations 3D-affine transformation and its extensions, DLT and terrain related RPCs should be avoided. The terrain related RPC solution cannot be controlled and should never be used. The DLT needs too many and three-dimensional well distributed control points and can fail, even if this is not shown at residuals of control points. Especially for original images the standard 3D-affine transformation and DLT are not usable. The 3D-affine transformation for original images with 14 unknowns needs more and 3D well distributed control points and can reach with a higher number of control points similar results like the strict solutions. In general the approximate orientation methods are not economic. With the geometric reconstruction and the bias corrected, sensor oriented RPC-solution with well defined control points usually pixel or sub-pixel accuracy can be reached even with a small number of control points.

It should be noted, that most of the commercial programs are not including some reliability information. Even if the discrepancies at the control points are small, poor results at check points may occur, requiring a check of the 3D-distribution of the used control points.

REFERENCES

- Büyüksalih, G., Akcin, H., Jacobsen, K., 2006: Geometry of OrbView-3 images, ISPRS Ankara Workshop 2006 Topographic Mapping from Space, WG I/5; I/6, <http://www.ipi.uni-hannover.de/> (accessed April 2008)
- Jacobsen, K., 1997: Calibration of IRS-1C PAN-camera, ISPRS Joint Workshop „Sensors and Mapping from Space“, Hannover 1997, <http://www.ipi.uni-hannover.de/> (accessed April 2008)
- Jacobsen, K., Passini, R., 2003: Comparison of QuickBird and IKONOS for the Generation of Orthoimages, ASPRS annual convention, Anchorage 2003
- Jacobsen, K., 2004: Analysis of Digital Elevation Models Based on Space Information, EARSeL Symposium Dubrovnik, 2004, in “New Strategies for European Remote Sensing”, Millpress ISBN 90 5966 003 X, pp 439 – 451
- Jacobsen, K., Crespi, M., Fratarcangeli, F., Giannone, F., 2008a: DEM Generation with Cartosat-1 stereo imagery, EARSeL Workshop Remote Sensing - New Challenges of High Resolution, Bochum 2008, + <http://www.ipi.uni-hannover.de/> (accessed April 2008)
- Jacobsen, K., 2008b: Tells the number of pixels the truth? – Effective Resolution of Large Size Digital Frame Cameras, ASPRS 2008 Annual Convention, Portland
- Kornus, W., Lehner, M., Schroeder, M., 1999: Geometric in-flight calibration by block adjustment using MOMS-2P-imagery of the three intersecting stereo-strips, ISPRS joint workshop “Sensors and Mapping from Space 1999”, Hannover, <http://www.ipi.uni-hannover.de/> (accessed April 2008)